

Meteor

In-ground Luminaires Series



Meteor



Meteor-S

- Die-Cast Aluminium body.
- 316 grade stainless steel frame.
- Installation with plastic outer housing.
- Outer key enables fitting to tilt without opening inside.
- Mains voltage: 220-240V / 50-60Hz.
- Spot, medium and wide beam angles available.
- Max. Weight resistance : 2000KG
- Convenient to be used with COB led.
- Led colour temperatures are optionally 2700K, 3000K, 3500K, 4000K and 5000K.
- Thermal shock resistant safety glass.
- Weatherproof and durable silicone rubber gasket.
- All external screws are stainless steel.
- High colour consistency: <3 SDCM
- Up to 135lm/W efficiency.

Recessed mounted uplight led wallwasher. Connecting cable and safety plug for portable installation. The used Led technique offers durability and optimal light output with low power consumption. The main body of the luminaires are Stainless steel that absorbs the pressure loads. The luminaires can be driven over by vehicles. Front frame is 316 grade Stainless steel resistant against high corrosion factors of outdoor conditions. In order to be easily flush mounted on ground, plastic mounting outer body is being supplied with the luminaire. Narrow, medium and wide symmetric light output with 30° adjustability.

Lightsource can be directed 30° to two directions.



Special key to adjust the direction of the light panel without opening the luminaire.



316 Grade stainless steel frame with inox outer screws.



Plastic outer mounting box for easy installation.



Light distribution





- Die-Cast Aluminium body.
- 316 grade stainless steel frame.
- Installation with plastic outer housing.
- Outer key enables fitting to tilt without opening inside.
- Mains voltage: 220-240V / 50-60Hz.
- Spot, medium and wide beam angles available.
- Max. Weight resistance : 2000KG
- Convenient to be used with COB led.
- Led colour temperatures are optionally 2700K, 3000K, 3500K, 4000K and 5000K.
- Thermal shock resistant safety glass.
- Weatherproof and durable silicone rubber gasket.
- All external screws are stainless steel.
- High colour consistency: <3 SDCM
- Up to 135lm/W efficiency.

Dimensions

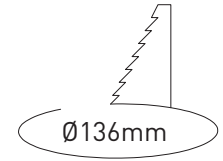
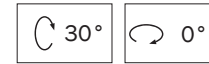
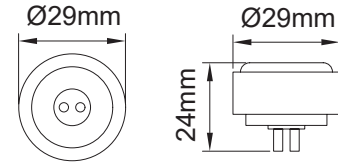
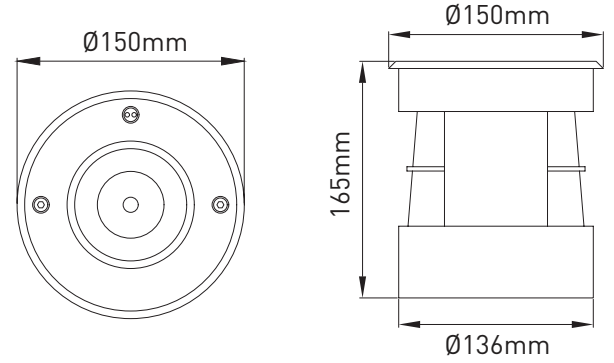

Light Distribution

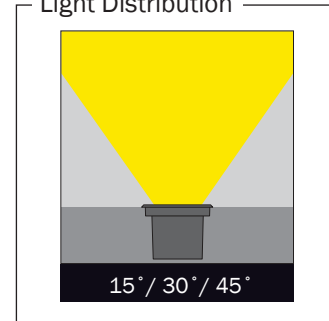

Meteor / [LGT.120.101](#)

Order Code	System Power	Kelvin / Color	Lumen Output	Dali Dimming Opt.	1-10V Dali Dimming Opt
LGT.120.101.01	6W	2700K	762	✓	✓
LGT.120.101.02	6W	3000K	778	✓	✓
LGT.120.101.03	6W	3500K	794	✓	✓
LGT.120.101.04	6W	4000K	810	✓	✓
LGT.120.101.05	6W	5000K	834	✓	✓



- Die-Cast Aluminium body.
- 316 grade stainless steel frame.
- Installation with plastic outer housing.
- Outer key enables fitting to tilt without opening inside.
- Mains voltage: 220-240V / 50-60Hz.
- Spot, medium and wide beam angles available.
- Max. Weight resistance : 2000KG
- Convenient to be used with COB led.
- Led colour temperatures are optionally 2700K, 3000K, 3500K, 4000K and 5000K.
- Thermal shock resistant safety glass.
- Weatherproof and durable silicone rubber gasket.
- All external screws are stainless steel.
- High colour consistency: <3 SDCM
- Up to 135lm/W efficiency.

Dimensions

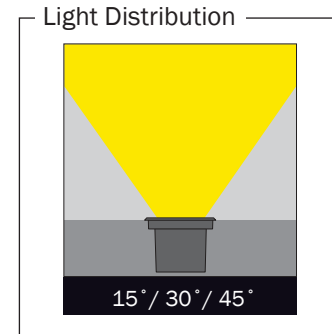
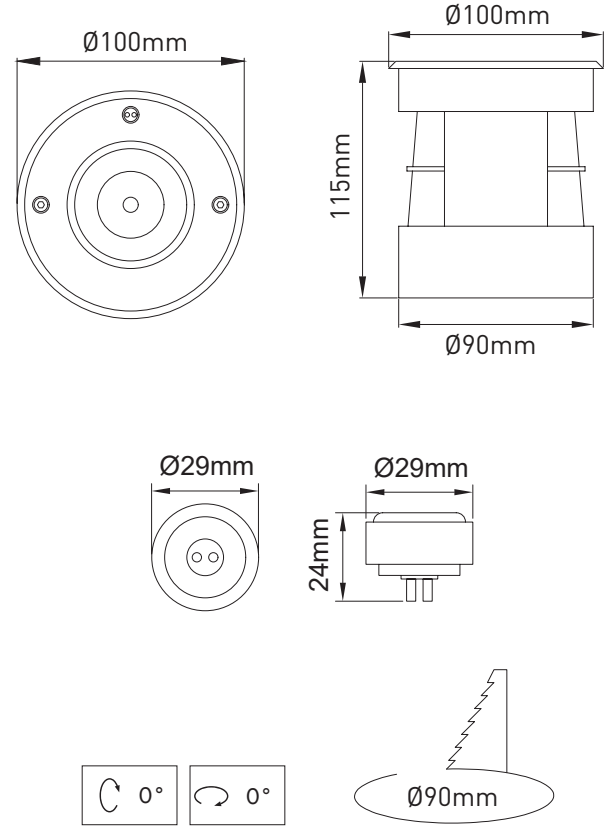

Meteor-S/ [LGT.120.101](#)

Order Code	System Power	Kelvin / Color	Lumen Output	Dali Dimming Opt.	1-10V Dali Dimming Opt
LGT.120.101.10	3W	2700K	381	✓	✓
LGT.120.101.11	3W	3000K	389	✓	✓
LGT.120.101.12	3W	3500K	397	✓	✓
LGT.120.101.13	3W	4000K	405	✓	✓
LGT.120.101.14	3W	5000K	417	✓	✓